

NX Thermal: Integrated thermal analysis

NX CAE

Benefits

- Reduce costly physical prototypes by using thermal simulation to understand product performance
- Shorten modeling time for initial and subsequent design-analysis iterations
- Gain further insight through coupled thermo-fluid multi-physics analysis using NX Thermal with NX Flow
- Understand thermo-elastic effects through coupled physics analysis with NX Nastran
- Leverage all the capabilities of the NX integrated environment to make quick design changes and provide rapid feedback on thermal performance

Summary

NX™ Thermal software provides heat transfer solutions and is an add-on module to either NX Advanced FEM or NX Advanced Simulation. NX Thermal can simulate conduction, convection and radiation phenomena for complex products and large assemblies. NX Thermal is used to address thermal analysis requirements in a wide range of industries including aerospace and defense, automotive and transportation, consumer products and appliances, energy, medical, electronics and semiconductors. In addition, NX Thermal can also be used with NX Flow, the NX-integrated CFD solution, for coupled thermo-fluid simulation.

FE-based finite volume thermal solver technology efficiently simulates heat transfer phenomenon

NX Thermal continues Siemens' long heritage in thermal simulation and leverages the same technology that underpinned the I-deas TMG solution. NX Thermal uses high-order finite volume-based technology on a FE mesh to accurately and efficiently simulate heat transfer phenomenon. It combines the versatility of FE-based analysis with the accuracy of a finite volume scheme. The NX Thermal solver technology allows simulation of NX parts and assemblies within complex thermal environments. The solver and modeling features include:

Solver capabilities

- Steady-state and transient solutions
- Material nonlinear thermal properties
- Axisymmetric modeling
- Iterative conjugate gradient solver technology
- Fully coupled conduction, radiation and convection heat transfer simulation
- 10 choices of consistent units to be used for runtime messages
- Mapping of temperatures to dissimilar structure FE model

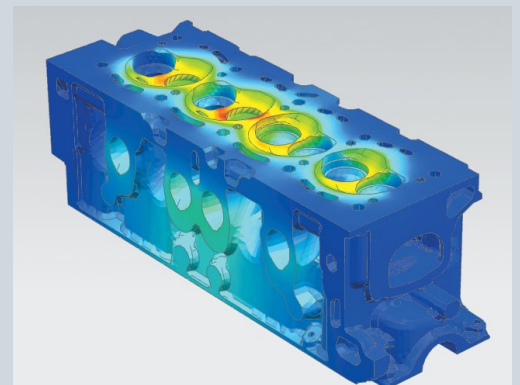

NX

www.siemens.com/nx

SIEMENS

NX Thermal

Element types supported in NX Thermal

- 0D concentrated mass
- 1D beam
- 2D triangular and quad thin shell, null shell, uniform and nonuniform multi-layer, linear or parabolic
- 3D linear or parabolic tetrahedral, brick, wedge and pyramid
- Linear and parabolic axisymmetric wedge and brick

Thermal couplings technology for modeling thermal contacts within NX assemblies

- Thermally connect disjoint and dissimilar mesh faces and edges
- Surface-to-surface, edge-to-edge or edge-to-surface contact modeling between parts: constant, time- or temperature-dependent coefficient of heat transfer, resistance or conductance
- Radiative exchange between disjoint part faces and faces within a single part
- Interface modeling between connected parts: constant, time- or temperature-dependent coefficient of heat transfer, thermal resistance or conductance, edge contact or conductive gap
- Spatially varying heat transfer coefficient can be defined for thermal couplings

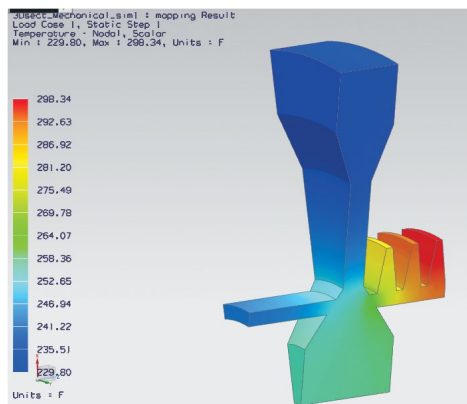

Applied heat loads

- Constant, time and spatially varying heat loads
- Constant, time and spatially varying heat flux
- Constant, time and spatially varying heat generation
- Ability to control all applied loads with temperature-controlled thermostat or PID controllers

Temperature boundary conditions

- Constant, time and spatially varying temperature
- Thermostat temperature controllers

Conduction heat transfer

- Ability to handle large conduction heat transfer models
- Temperature-dependent conductivity
- Temperature-dependent specific heat
- Orthotropic conductivity
- Phase change at temperature or over temperature range

Convection heat transfer

- Constant, time and spatially varying heat transfer coefficient and environment temperature
 - Parameter and nonlinear temperature gradient functions
- Free convection

Correlation-based free convection to ambient for inclined plates, cylinders and spheres and parallel plate channels

Forced convection

Correlation-based convection for plates, spheres and cylinders in forced fluid flow

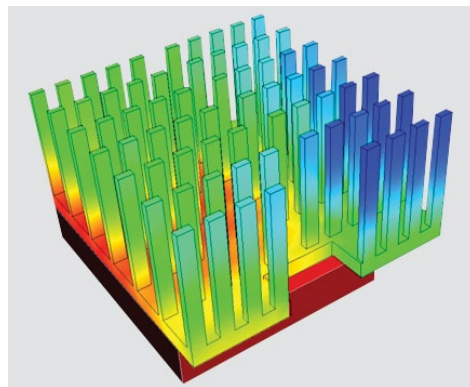

Radiation heat transfer

- Constant and temperature-dependent emissivity
- Multiple radiation enclosures
- Diffuse view factor calculations with shadowing
- Net view factor calculations
- Adaptive scheme for view factor sum optimization
- Hemispherical view (form) factors calculation using graphics card hardware
- Radiation patch generation to condense large element-based radiation models
- Radiation matrix controls and parameters

Initial conditions

- Starting temperatures for both steady-state and transient
- Starting temperatures from previous solution results, from file

Solver and solution attributes

- Direct access to solver parameters
- Solver convergence criteria and relaxation factors
- Restart conditions, cyclic convergence criteria
- Solver monitor with solution convergence and attributes
- Intermediate results display and recovery directly from solver progress monitor

Other features

- Result reports
Summary of results to html pages and comma separated value (.csv) files compatible with Excel
Heat flow calculation between groups
Heat maps
- Complete or partial deactivation of selected elements (for radiation form factors calculations)
- Temperature mapping for Nastran FE models with dissimilar mesh

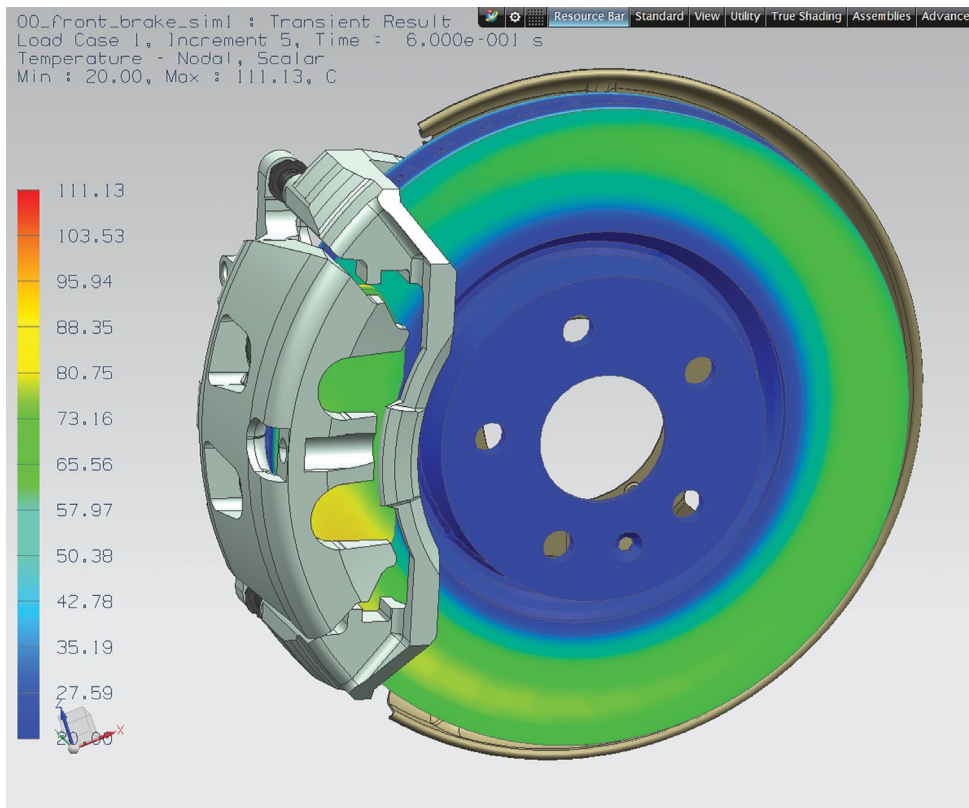

Simulation results

- Temperatures
- Temperature gradients
- Total loads and fluxes
- Conductive fluxes
- Convective fluxes
- Convection coefficients
- Residuals
- Heat maps
- View factors sums

Simulation features

Thermal couplings for joining disjoint solid or surface meshes within NX assembly context

Thermal couplings provide a powerful and efficient capability for building assemblies by modeling heat

flow between unconnected parts and components. Multiple what-if scenarios and positioning of parts within an assembly can be investigated by defining the thermal coupling parameters between unconnected parts only once. Heat transfer paths are automatically created between elements on opposing parts at runtime. These conductances are established based on surface proximity, and account for overlap and mismatch between disjoint and dissimilar meshes exchanging heat, allowing parts to be moved freely within the assembly prior to running the analysis. Thermal coupling types include conductive, radiative and interface couplings. Thermal couplings can also be defined as varying with temperature or time and space location.

Coupled thermo-fluid and thermo-elastic simulations

The heat transfer modeling capabilities can be explicitly combined with the NX Flow or NX Advanced Flow computational fluid dynamics (CFD) solution (also available within the NX Advanced Simulation environment).

These combinations allow a user to simulate fully-coupled thermo-fluid interactions problems, including integration of radiative heat transfer. When NX Flow and NX Thermal are purchased together, the thermo-fluid simulation capability is automatically activated within NX

at no additional cost, offering both conduction and radiation modeling to be fully coupled with 3D fluid flow. Furthermore, NX Thermal temperature results can be mapped to a separate Nastran FE model for thermo-elastic analysis.

Native to NX, integrated thermal and heat transfer solution

NX Thermal is integrated within the native NX portfolio and takes full advantage of the NX Advanced FEM environment including synchronous technology, allowing quick geometry modifications without regard to how it was built, as well as the distributed meshing workflows leveraging the Assembly FEM capabilities. The NX

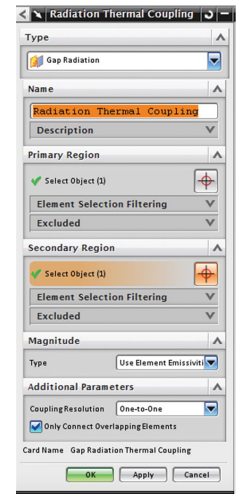

integrated application allows both skilled engineers and thermal specialists to avoid any additional transfer of input files or geometry conversions and manipulations breaking the associative link between the NX geometry and FE tasks. The thermal model is synchronized with the NX design and assembly intent through NX data associativity. Complete associativity with the design geometry means that the thermal mesh is automatically updated when the design or assembly is modified.

NX provides NX Thermal users with a broad set of tools for creating thermal models and analysis-ready geometry. A user can automatically (or manually) create an idealized part where easy abstraction of unnecessary geometrical features can be achieved. Every geometrical abstraction is associative to the NX part and assembly context. Automated free meshing tools enable

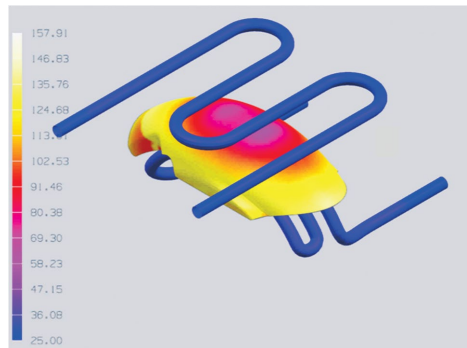

quick parts modeling using precise sketches, surfaces and solid geometry. The user can refine the mesh in critical areas and selectively control mesh density, minimizing or optimizing model size for rapid and accurate solution.

By virtue of being integrated within the NX environment, NX Thermal provides the ability to model, catalog and share parts and material libraries among the NX design team, thereby minimizing tedious rework and potentially costly modeling errors.

Product availability

NX Thermal is an add-on module in the suite of Advanced Simulation applications available within the NX architecture. It requires a core seat of either NX Advanced FEM or NX Advanced Simulation as a prerequisite. When used in combination with NX Flow, NX Thermal provides a coupled multiphysics solution for complex fluid flow/thermal applications.

NX Thermal is available on most major hardware platforms and operating systems including Windows and Linux.

Contact
Siemens Industry Software
Americas +1 800 498 5351
Europe +44 (0) 1276 702000
Asia-Pacific +852 2230 3333

www.siemens.com/plm

© 2011 Siemens Product Lifecycle Management Software Inc. All rights reserved. Siemens and the Siemens logo are registered trademarks of Siemens AG. D-Cubed, Femap, Geolus, GO PLM, I-deas, Insight, JT, NX, Parasolid, Solid Edge, Teamcenter, Tecnomatix and Velocity Series are trademarks or registered trademarks of Siemens Product Lifecycle Management Software Inc. or its subsidiaries in the United States and in other countries. Nastran is a registered trademark of the National Aeronautics and Space Administration. All other logos, trademarks, registered trademarks or service marks used herein are the property of their respective holders. X26 6709 12/11 B